

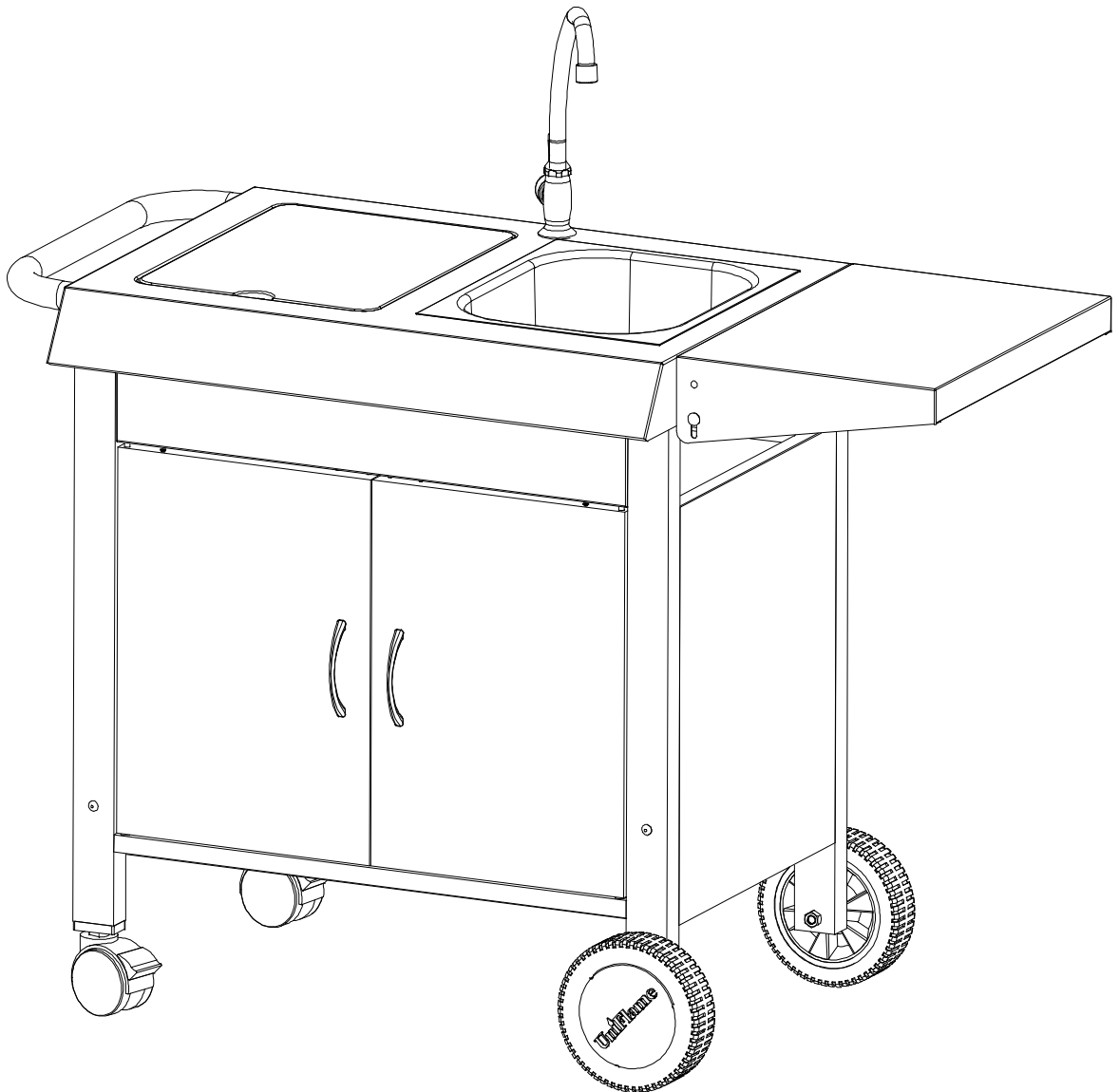

***Model SC2001-1S deluxe
outdoor serving cart***



SAVE THESE INSTRUCTIONS FOR FUTURE REFERENCE. IF YOU ARE ASSEMBLING THIS UNIT FOR SOMEONE ELSE, GIVE THIS MANUAL TO HIM OR HER TO SAVE FOR FUTURE REFERENCE.



Owner's Manual,
SC2001-1S serving cart

Dear Valued Customer,











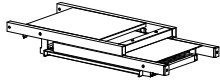

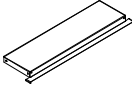

Congratulations on your new serving cart: You've made the right choice! In this manual, you will find assembly instructions, suggestions, and helpful hints, as well as guidelines for the safe operation, proper care of, and use of your serving cart. Our expert staff strives to provide you with an easy to assemble product. However, in the unlikely event that a part is missing or defective, please call our customer satisfaction department seven days a week at (800) 762-1142 from 8 a.m. to 5 p.m. central standard time. You also can fax your request to (847) 731-6032. When faxing, please include your name, address, model number, part needed, and the name of the store where you purchased your grill. We then will ship your request as soon as possible. We appreciate and encourage customer feedback. Please contact us if you have any suggestions or comments regarding this product.

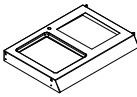
Best Regards,

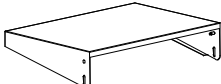
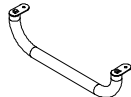
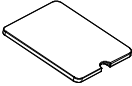

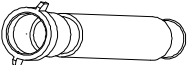

UniFlame Corporation
Customer Satisfaction Department

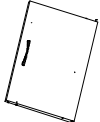
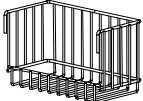
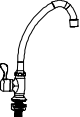

IMPORTANT NOTICE: READ ALL INSTRUCTIONS PRIOR TO ASSEMBLY AND USE!

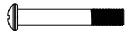
Illustrated parts list

<p>1. Cart Frame.....1 pc</p> 	<p>2. Lockable Caster.....2pcs</p> 	<p>3. Wheel.....2pcs</p> 
<p>4. Wheel Decal.....2pcs</p> 	<p>5. Front Support Plate..... 1pc</p> 	<p>6. Back Support Plate..... 1pc</p> 
<p>7. Upper Frame..... 1pc</p> 	<p>8. Water Supply Hose.....1pc</p> 	<p>9. Side Shelf.....1pc</p> 
<p>10. Side handle.....1pc</p> 	<p>11. Cutting Board.....1pc</p> 	<p>12. Ice Bucket.....1pc</p> 
<p>13. Sink.....1pc</p> 	<p>14. Sink Drain.....1pc</p> 	<p>15. Drain Gate.....1pc</p> 
<p>16. Drain Hose.....1pc</p> 	<p>17. Left Door.....1pc</p> 	<p>18. Right Door.....1pc</p> 
<p>19. Basket.....2pcs</p> 	<p>20. Faucet.....1pc</p> 	

Illustrated hardware list

A		Large Bolts	2pcs
B		Large Nuts	2pcs
C		Medium bolts	10pcs
D		Screwdriver	1pc
E		Wing Nuts	2pcs

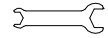
F		Lock washers	2pcs
G		Flat washers	2pcs
H		Small Bolts	2pcs
I		Wrench	1pc



Owner's Manual, SC2001-1S serving cart

Assembly Instructions

For Best Results

Remove all contents from packaging, and make sure all parts are present before attempting to assemble! Tighten all bolt connections by hand first, then when the serving cart is fully assembled, go back and tighten.

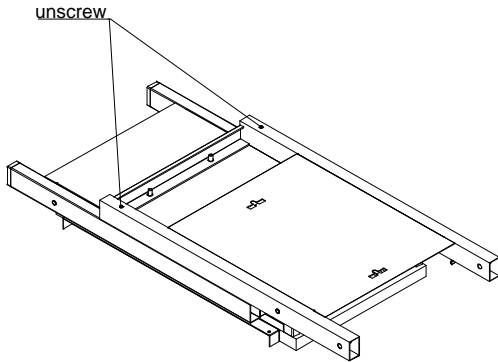

Step 1

Unscrew two bolts on wagon, as shown.

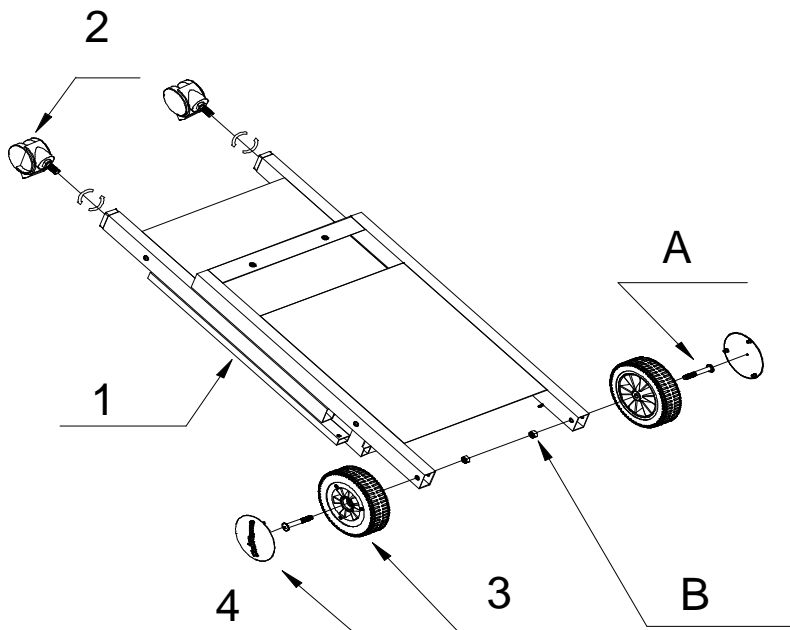
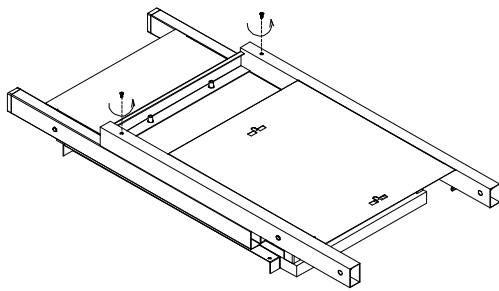

Step 2

Attach two lockable casters (2) to cart frame (1), by screwing casters into frame legs with holes, as shown. Then, secure two wheels (3), to frame's other two legs using large bolts (A) and large nuts (B), as shown. Cover wheels with wheel decals (4) after the wheels are attached to frame.

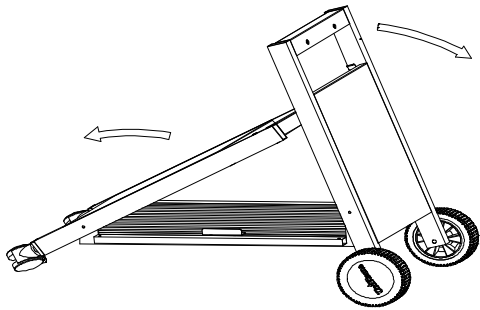

Step 3

Unfold cart frame, as shown.

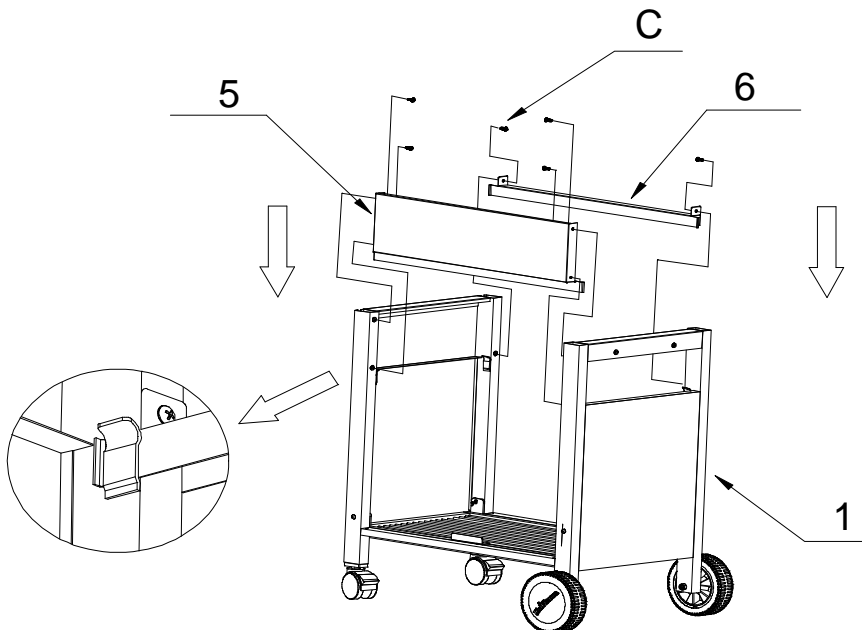
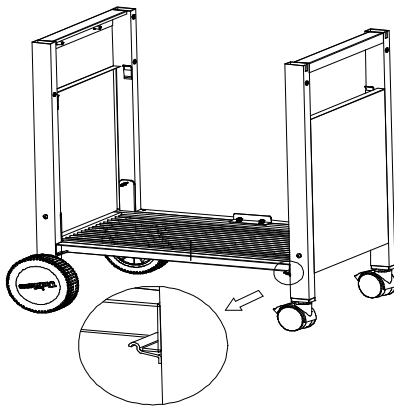

Step 4

Slide front-support plate (5), and back support plate (6) into place on cart, as shown, securing with medium bolts (C). Note: make sure that the cart's wheels are on the right as you look at the cart, and insert the front plate on the side closest to you, as shown.

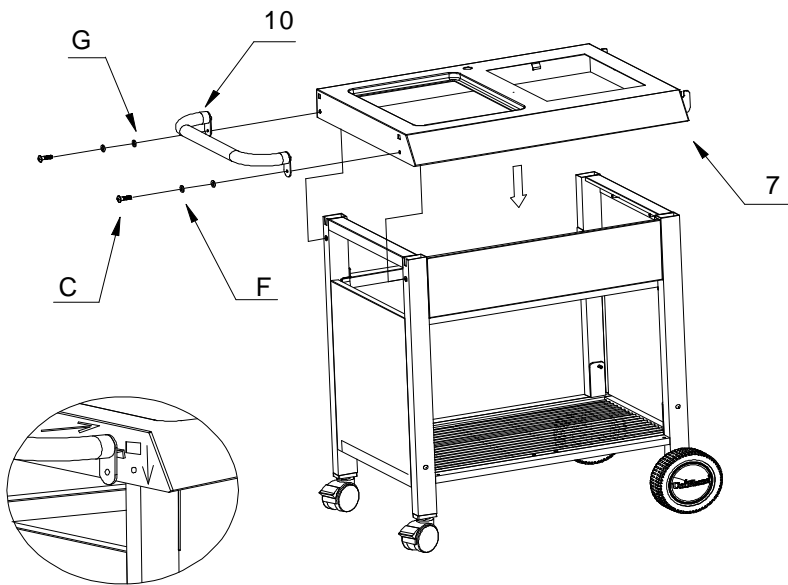

Step 5

Place upper frame (7) on top of assembled cart, assuring that the slanted front of upper frame faces the front support plate, installed in previous step. Attach side handle (10) to cart using medium bolts (C), lock washers (F) and flat washers (G).

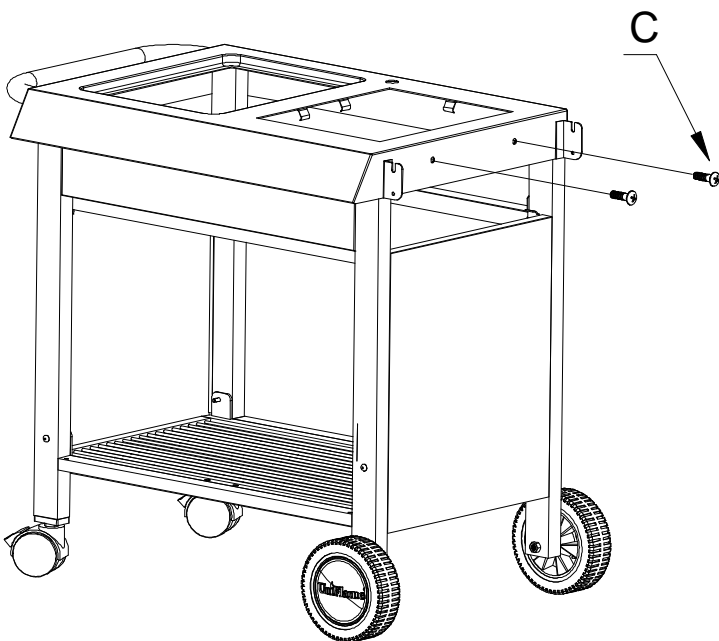

Step 6

Secure upper frame using medium bolts(C).

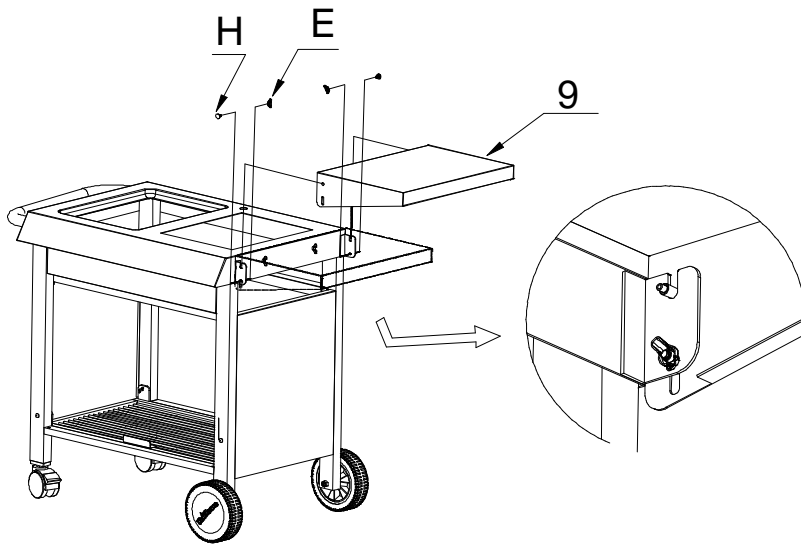

Step 7

Attach side shelf (9) to frame on right side (same side as wheels) by sliding directly downward onto shelf supports, and securing with small bolts (H), and wing nuts (E).

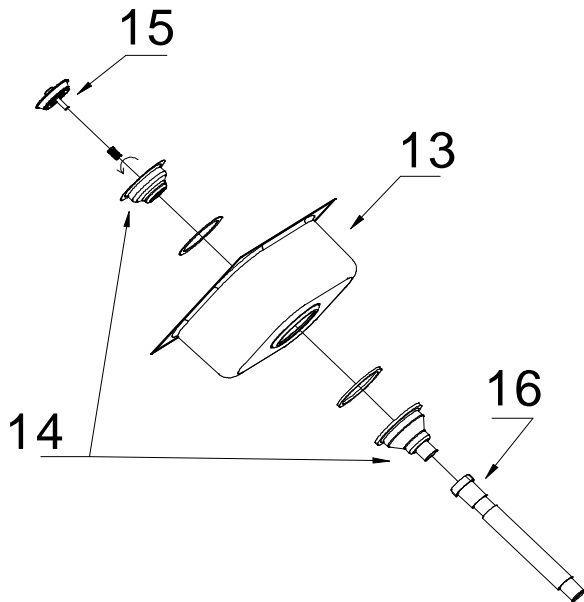

Step 8

Assemble sink, as shown, by separating sink drain (14), as shown, and re-assembling by attaching to sink (13), as shown. Insert drain grate (15) on inside of sink, and attach drain hose (16) to bottom of sink drain, as shown.

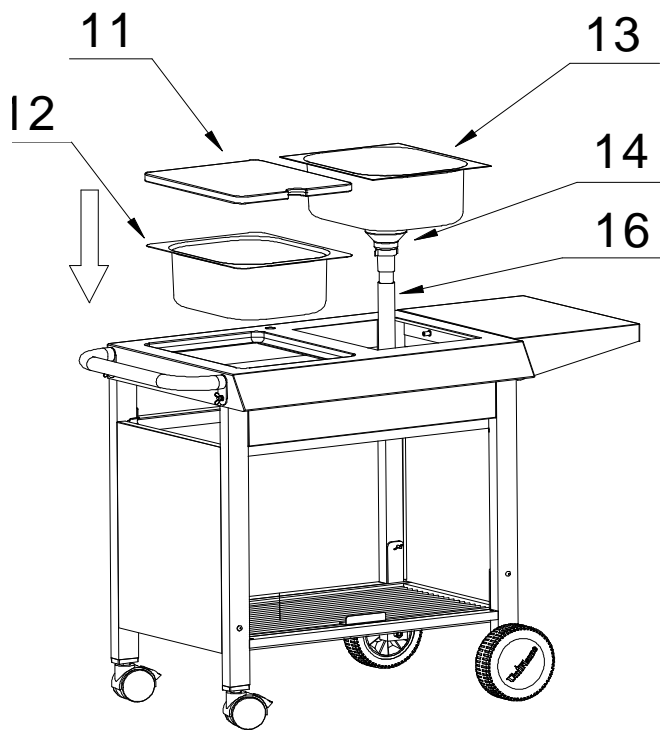

Step 9

Insert ice bucket (12), and cutting board (11), into left side of the upper frame, as shown. Then put assembled sink into right side of upper frame, as shown.

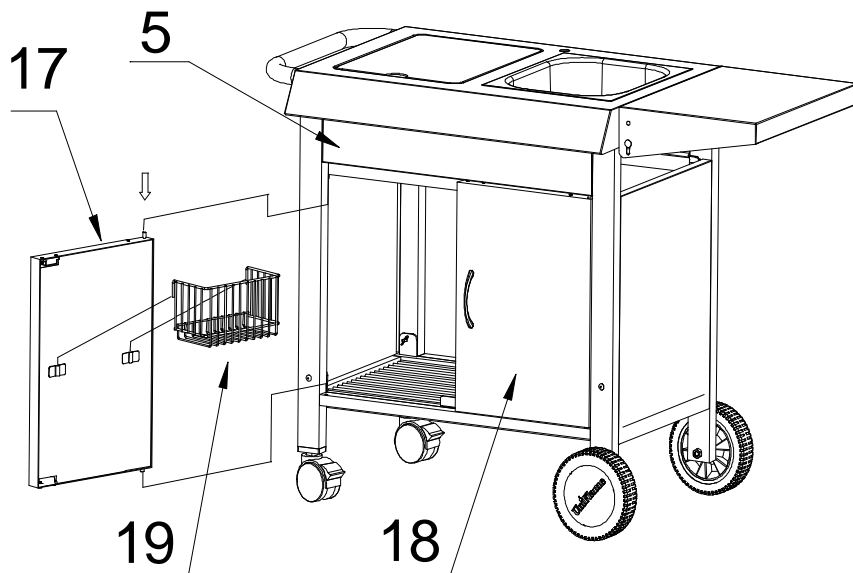

Step 10

Attach left door (17) and right door (18) as shown. Next attach baskets (19) to left doors by inserting into brackets on inside of doors as shown.

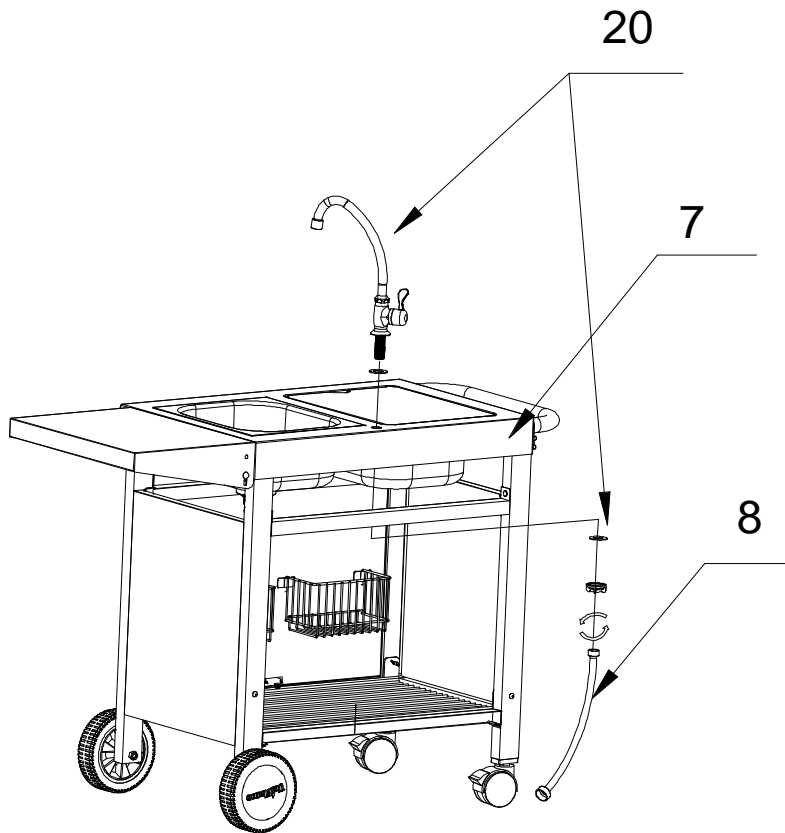

Step 11

Attach faucet (20) to sink as shown, by separating and threading into hole in sink and securing with ring underneath sink. Then attach water supply hose (8) to bottom of faucet.

Sink drain hose (16) can be extended to drain water into yard, or a bucket can be set inside cart to catch water.



1 YEAR LIMITED WARRANTY

UniFlame Corporation warrants to the original retail purchaser of this serving cart that if it is assembled and operated in accordance with the printed instructions accompanying it then for a period of one (1) year from the date of purchase. All parts shall be free from defects in material and workmanship. UniFlame may require reasonable proof of your date of purchase. Therefore, you should retain your sales slip or invoice.

This Limited Warranty shall be limited to the repair or replacement of parts, which prove defective under normal use and service and which on examination, shall indicate, to UniFlame's satisfaction, they are defective. Before returning any parts, contact UniFlame's Customer Service Department. If UniFlame confirms the defect and approves the claim, UniFlame will elect to replace such parts without charge. If you are required to return defective parts, transportation charges must be prepaid. UniFlame will return parts to the purchaser, freight or postage prepaid.

This Limited Warranty does not cover any failures or operating difficulties due to accident, abuse, misuse, alteration, misapplication, improper installation or improper maintenance or service, or failure to perform normal and routine maintenance, as set out in this owners manual. There are no other express warranties except as set forth herein and any applicable implied warranties of merchantability and fitness are limited in duration to the period of coverage of this express written Limited Warranty. Some states do not allow limitation on how long an implied warranty lasts, so this limitation may not apply to you.

UniFlame is not liable for any special, indirect or consequential damages. Some states do not allow the exclusion or limitation of incidental or consequential damages, so this limitation or exclusion may not apply to you.

UniFlame does not authorize any person or company to assume for it any other obligation or liability in connection with the sale, installation, use, removal, return, or replacement of its equipment, and no such representations are binding on UniFlame.

UniFlame Corporation
1817 N. Kenosha Road
Zion, Illinois 60099, USA
(800) 762-1142
24 Hour Fax: (847) 731-6032